

Kinematic Coupling for Precision Fixturing & Assembly

Folkers E. Rojas, MS & Nevan C. Hanumara, PhD
MIT Precision Engineering Research Group

1 February 2013

material from

Profs. Alexander H. Slocum & Martin Culpepper

<http://pergatory.mit.edu/>

<http://www.kinematiccouplings.org/>

OUTLINE

- Kinematic Coupling Overview
- Hertz Contact Review
- Types
 - Standard
 - Canoe (High Load)
 - Compliant
 - Three Tooth
- Case Studies
 - Servo Controlled
 - Ford (Duratec™) QKC
- Elastic Averaging

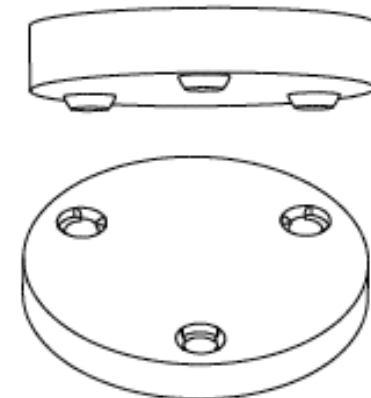
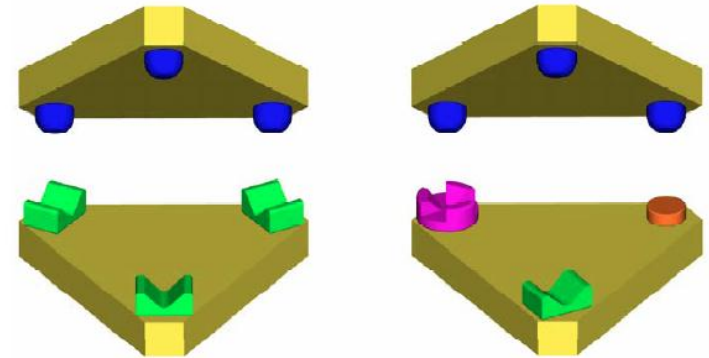

Review of Coupling Methods



Elastic Averaging
Non-Deterministic

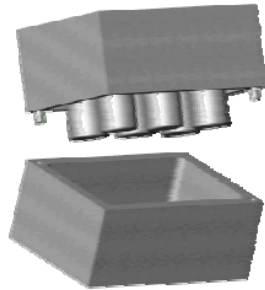

Pinned Joints
No Unique Position

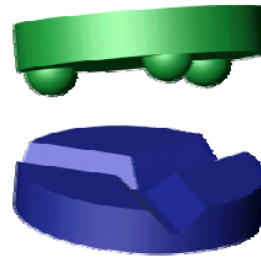

Kinematic Couplings
Kinematic Constraint



Flexural Kin. Couplings
Kinematic Constraint

	0.01 μm	0.1 μm	1 μm	10 μm	100 μm
Pinned Joints			▶		
Flexural Kinematic Couplings			▶		
Elastic Averaging			▶		
Quasi-Kinematic Coupling		▶			
Kinematic Couplings	▶				

Kinematic Coupling Overview

- When a component is constrained by a number of points equal to the number of degrees of freedom, it is said to be exactly constrained.
 - # Points of Contact = # Degrees of Freedom Constrained
- Low-Medium Force Precision Applications
- Do Not Allow Sealing Contact
- Moderate Stiffness
- Moderate Cost
- Excellent repeatability
 - 1/4 micron common
 - On order of surface Finish

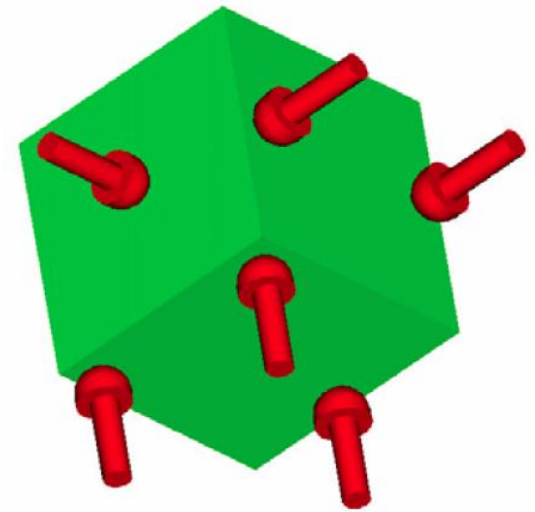

Key Hertz Relations

- Contact Pressure is proportional to:
 - Force to the $1/3^{\text{rd}}$ power
 - Radius to the $-2/3^{\text{rd}}$ power
 - Modulus to the $2/3^{\text{rd}}$ power
- Deflection is proportional to:
 - Force to the $2/3^{\text{rd}}$ power
 - Radius to the $-1/3^{\text{rd}}$ power
 - Modulus to the $-2/3^{\text{rd}}$ power
- Contact ellipse diameter is proportional to:
 - Force to the $1/3^{\text{rd}}$ power
 - Radius to the $1/3^{\text{rd}}$ power
 - Modulus to the $-1/3^{\text{rd}}$ power
- **CAREFUL TO NOT ALLOW THE CONTACT ELLIPSE TO BE WITHIN ONE DIAMETER OF THE EDGE OF A SURFACE!**

Standard KC

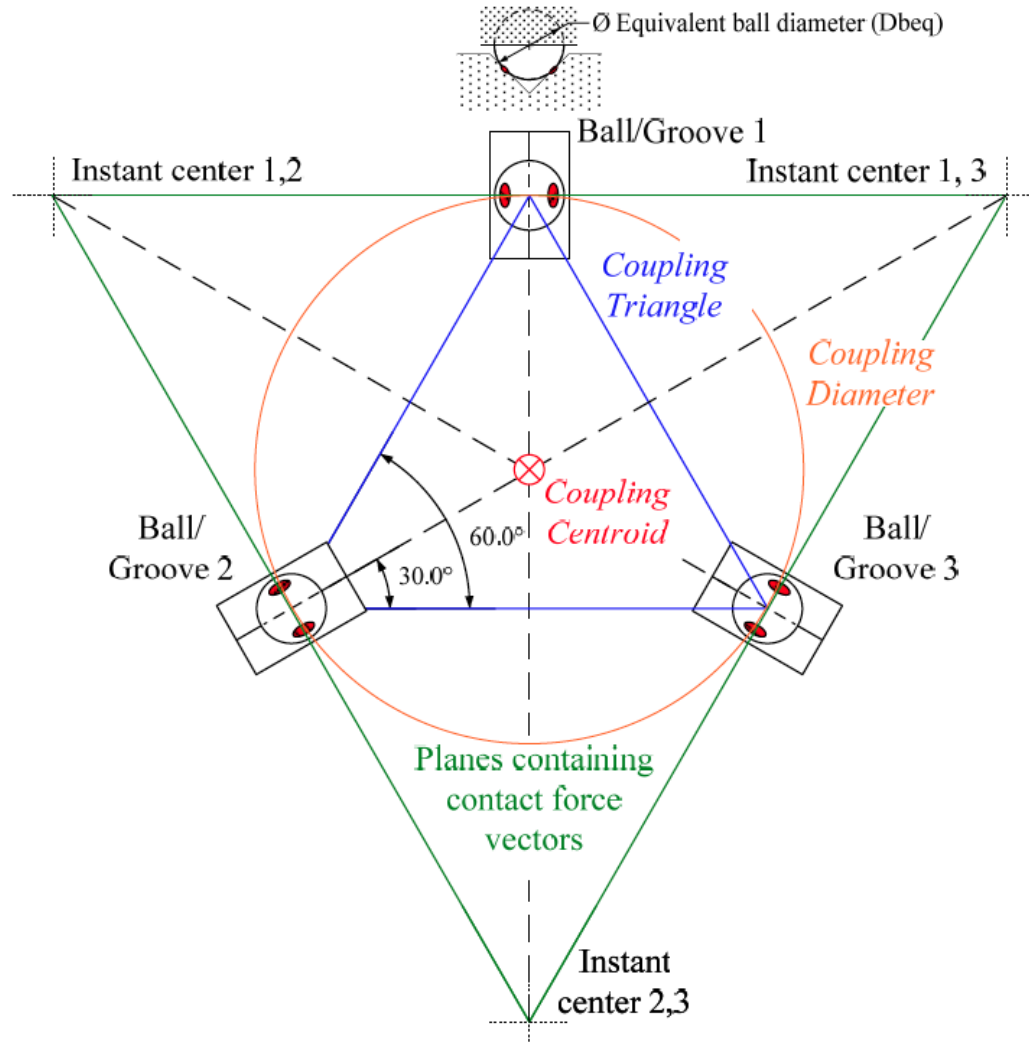

Canoe-Ball Kinematic Interface for High Load Applications

- The “Canoe Ball” shape acts like a 1m diam ball
- 100 times the stiffness & load of normal 1” ball
- 10 times load capacity of crowned cone
- Large Shallow Hertzian zone (very repeatable)
- US Patent 5,711,647



Compliant Kinematic Couplings

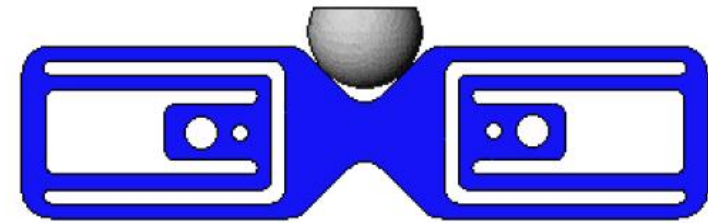
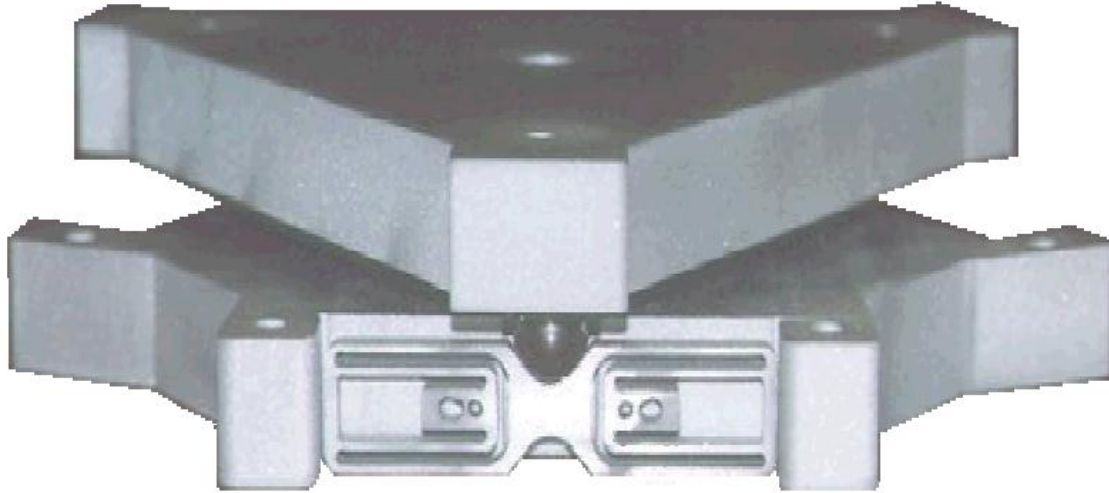

Not Flexed

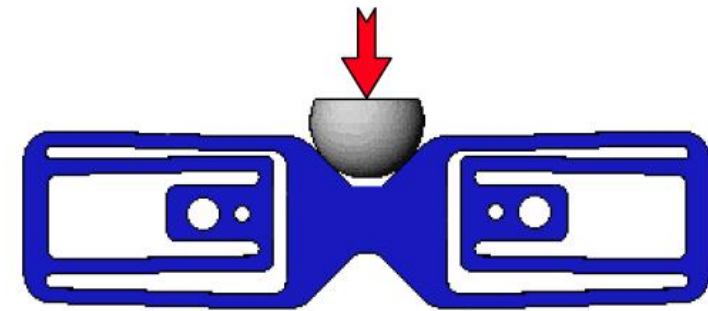

Flexed

- Clamping Load/Friction/Mated Surface
- Joint Location
- Compliant Members
- Kinematic Interface

Compliant Kinematic Couplings



- Characteristics
 - Low Cost
 - Small – Medium Stroke
 - Precision 5 – 10 μm
- Applications/Process
 - Assembly Lines
 - Stamping, Forging, Forming Equipment Die Alignment
 - Semiconductor Manufacturing Equipment
 - Casting Dies
- Cost
 - \$10 – 200

Compliant Kinematic Couplings

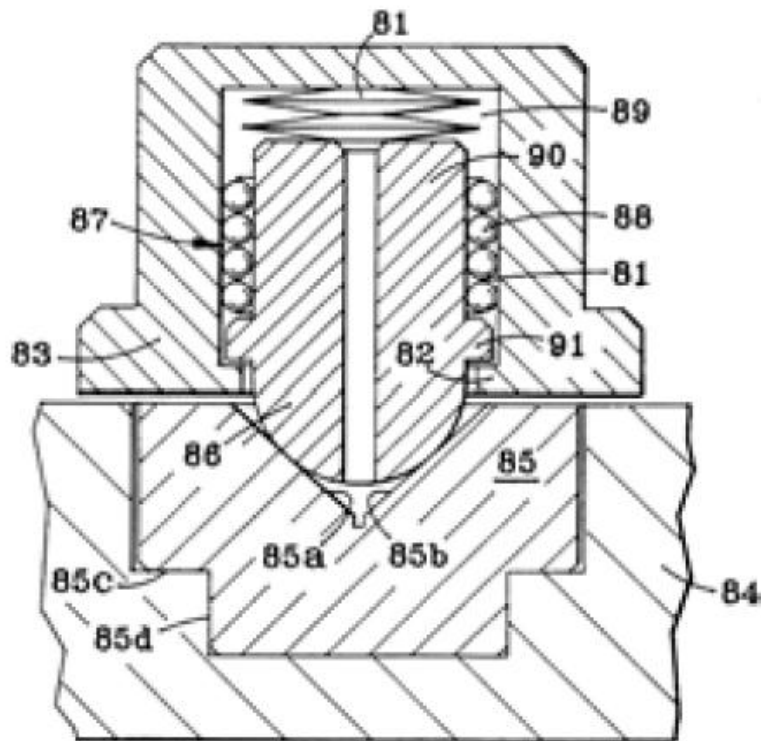

- Characteristics
 - Medium Cost
 - Long Stroke
 - Precision 2.5 μm
- Applications/Process
 - Assembly Lines
 - Casting
 - Fixtures
- Cost
 - \$2000

Three Tooth

- Semi-kinematic
- 6 point mating
- 3-5 micron repeatability
- Layton Hale (LLNL) added crowns to 1 set teeth yielding 1 micron repeatability

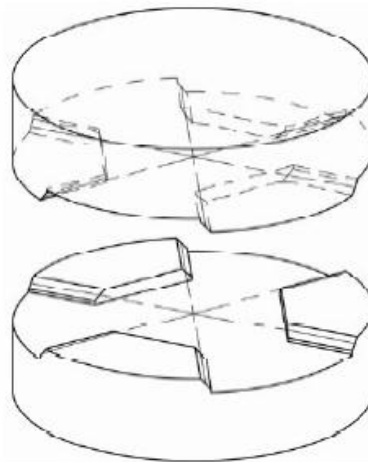
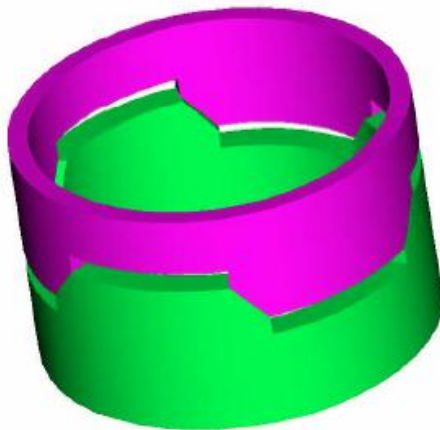

United States Patent [19] **Patent Number:** 6,065,898
Hale [45] **Date of Patent:** *May 23, 2000

[54] **THREE TOOTH KINEMATIC COUPLING**

[75] **Inventor:** Layton C. Hale, Livermore, Calif.

[73] **Assignee:** The Regents of the University of California, Oakland, Calif.

[*] **Notice:** Under 35 U.S.C. 154(b), the term of this patent shall be extended for 634 days.

[21] **Appl. No.:** 08/511,880

[22] **Filed:** Aug. 7, 1995

[51] **Int. Cl.:** F16D 1/00

[52] **U.S. Cl.:** 403/364; 403/190; 403/340; 403/381; 464/157; 192/69.83

[36] **Field of Search:** 403/190, 291, 403/364, 311, 340, 381; 192/114 T, 69.81, 69.82, 69.83; 464/149, 157

[56] **References Cited**

U.S. PATENT DOCUMENTS

1,241,118	9/1917	Hedrick	464/157
1,262,691	5/1918	Lady	403/364 X
1,739,756	12/1929	Greenley	464/149
2,064,416	9/1937	Sheffield	403/364 X
2,384,583	9/1945	Wilkhaber	192/69.85
2,388,456	11/1945	Wilkhaber	464/157 X
2,558,570	4/1946	Wilkhaber	403/364 X
2,551,735	5/1951	Geß	464/149
2,654,456	10/1955	Wilkhaber	192/69.83 X
4,074,946	5/1978	Sveinsson	403/364
4,507,795	12/1981	Ray	192/69.82
5,732,857	3/1996	Olgen	464/157

FOREIGN PATENT DOCUMENTS

85226	12/1938	France	463/564
14965	7/1968	Japan	464/157
578207	6/1946	United Kingdom	464/157

OTHER PUBLICATIONS

A. Slocum, Precision Machine Design, Prentice Hall, 1992, pp. 401-402.

D.L. Blanding, Principles of Exact Constraint Mechanical Design, Eastman Kodak Co., 1992, pp. 28-29.

Machinery handbook, 24th Edition, Couplings and Clutches, Industrial Press, 1992, pp. 2257-2258.

Private Examiner: Daniel P. Studola
Assistant Examiner: Bruce A. Les
Attorney Agent, or Firm: Alan H. Thompson; L. E. Cavonius

[57] **ABSTRACT**

A three tooth kinematic coupling based on having three theoretical line contacts formed by mating teeth rather than six theoretical point contacts. The geometry requires one coupling half to have curved teeth and the other coupling half to have flat teeth. Each coupling half has a relieved corner portion which does not effect the kinematics, but in the limit as the face width approaches zero, three line contacts become six point contacts. As a result of having line contact, a three tooth coupling has greater load capacity and stiffness. The kinematic coupling has application for use in precision fixturing for tools or workpieces, and as a registration device for a work or tool changer or for optics in various products.

15 Claims, 2 Drawing Sheets

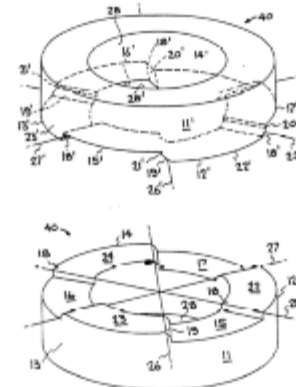

Wafer Transport

- How to precisely locate a plastic wafer carrying structure (FOUP) on a tool, so a robot can precisely load/unload wafers?
 - Exactly constrain it of course with an interface that contacts the FOUP at 6 unique points!
 - Success requires management of contact stresses, and standards upon which manufacturers agree
 - SEMI E57-1296 kinematic coupling standard for wafer transport pods

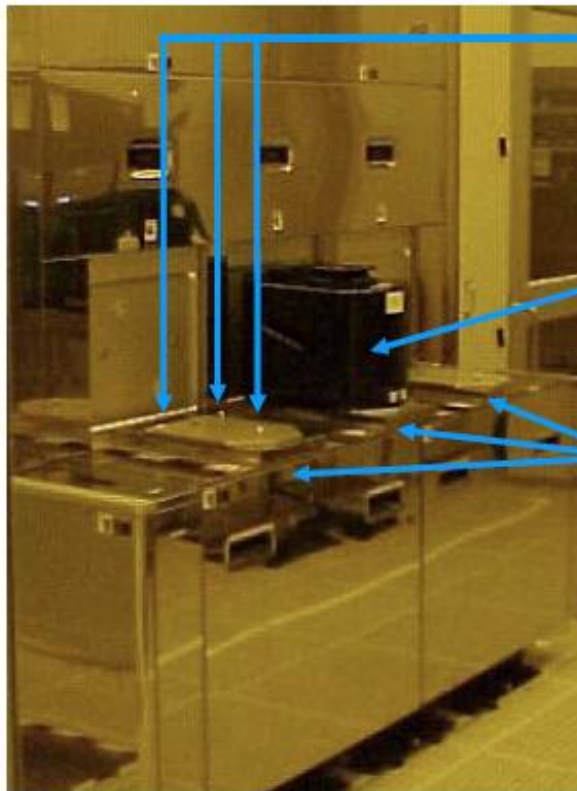

Kinematic coupling pins on loadport based on SEMI E57 standard

300mm Wafer carrier (FOUP) precisely positioned on kinematic coupling pins on loadport

Production equipment loadports based on SEMI E15.1 standard



Base of the FOUP

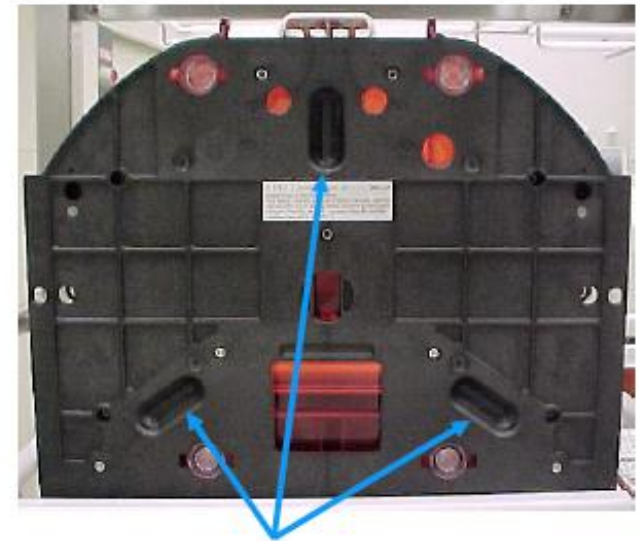

Mating kinematic coupling grooves on the FOUP, permitting precise alignment on load ports, so robots can precisely access 300 mm wafers

Ford 2.3 L V-6 Duratec™

COMPONENTS



Block



Bedplate



ASSEMBLY

Assembly Bolts

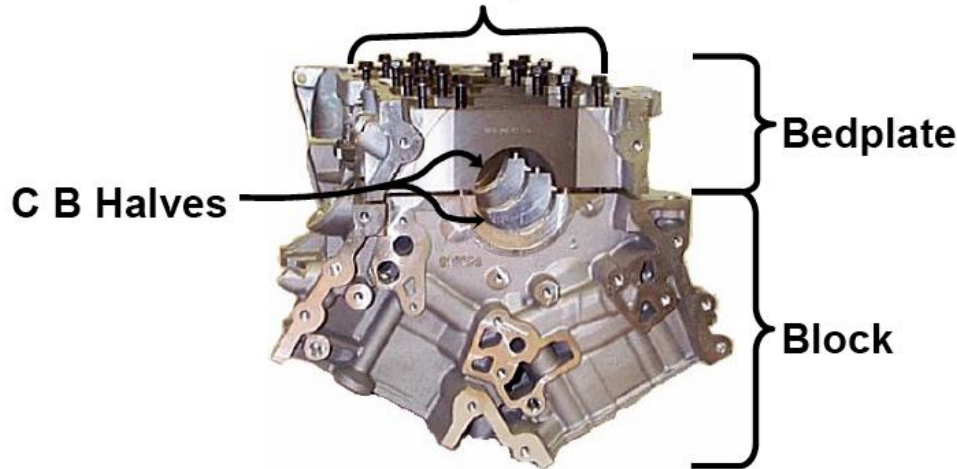

ERROR

δ_e MAX = 5 microns

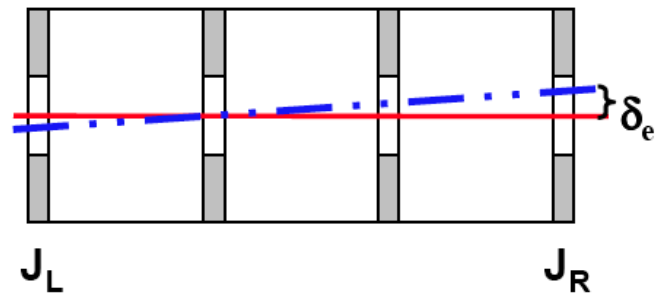

— · — Block Bore \varnothing

— Bedplate Bore \varnothing

Quasi Kinematic Couplings (QKCs)



- What is a QKC & why is it important
 - Attain Sub-Micron Repeatability
 - Use Less Restrictive Tolerances
 - Have More Flexibility in Assigning Precision Tolerances
- Impact
 - Better Precision At Lower Cost
 - Extension of Practical HVM Precision
 - Eliminate Precision Pinned Joints (0.5 -10 microns)
 - Reduce Number of Parts

QKCs Physical Components

- Arc Contact
- Sub-micron Precision
- Stiffness Increase
- Sealing Contact

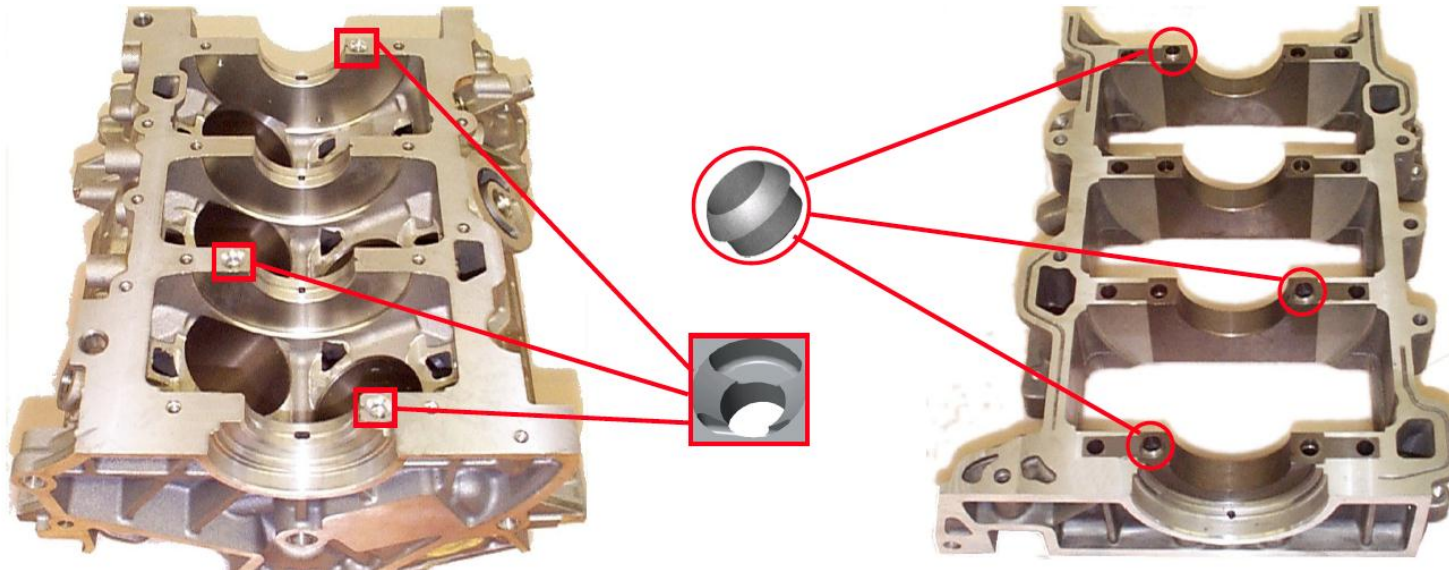
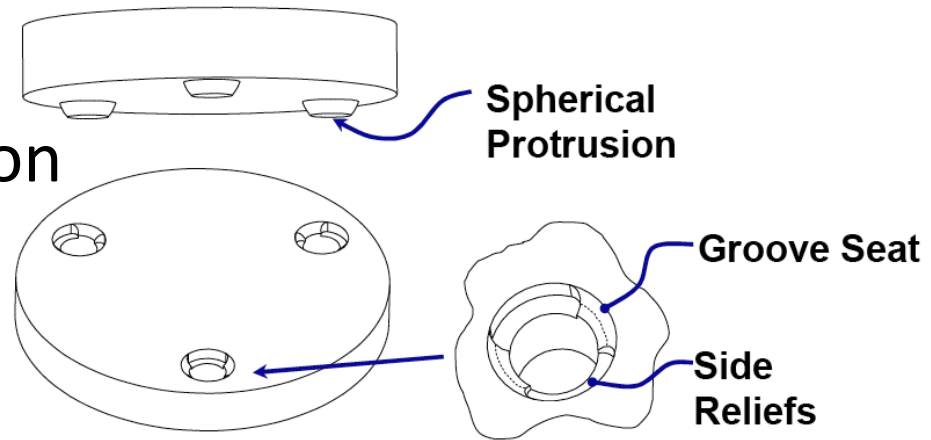

QKC Design

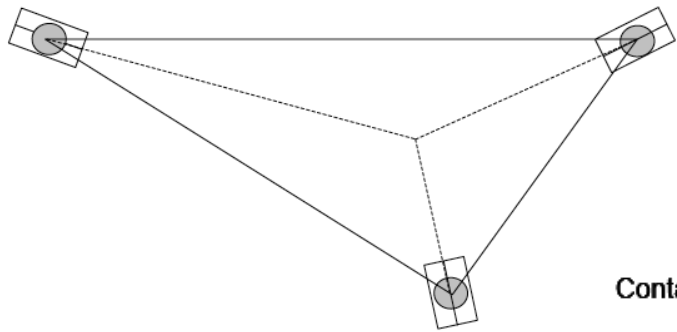

Kinematic Coupling

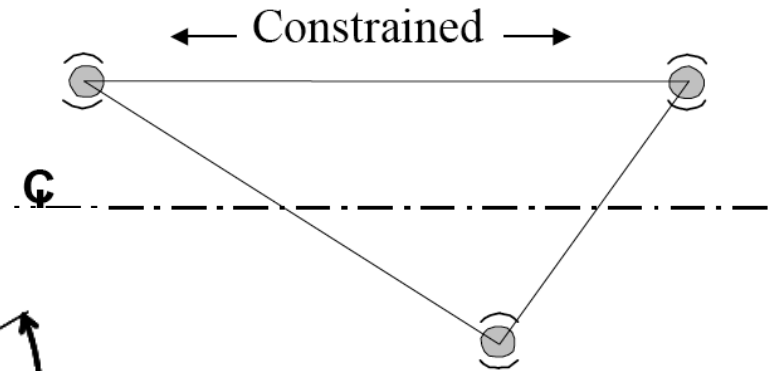

Aligned QKC

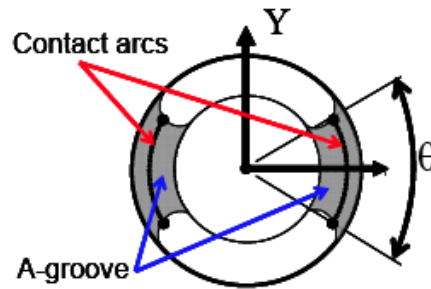

GROOVE MANUFACTURING

ASSEMBLED JOINT



CAST

FORM TOOL

FINISHED

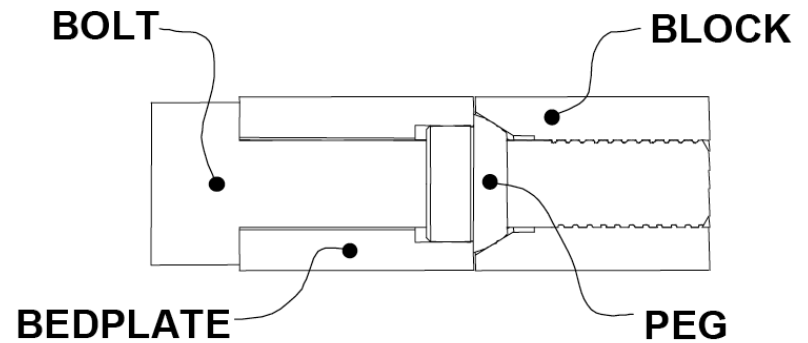

QKC Contact Mechanics

- Assume Hertzian Line Contact Profile
- Specify Profile in Rotating Coord. System
- Integrate Profile to get forces

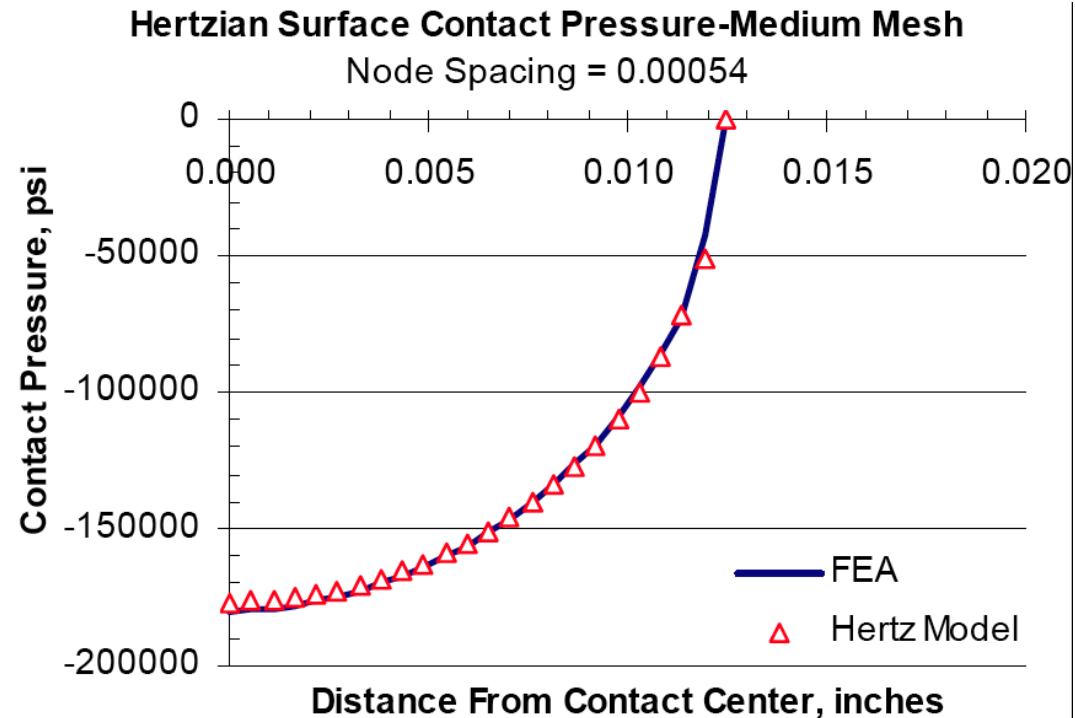
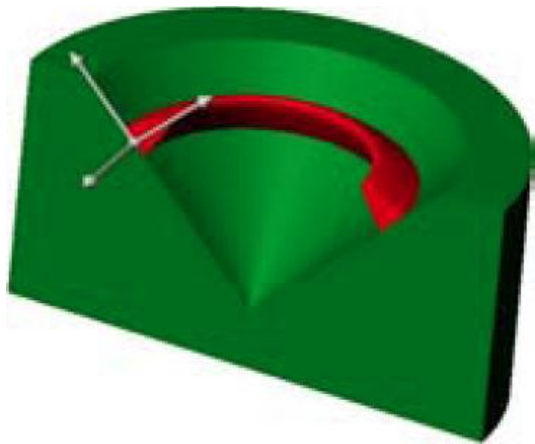
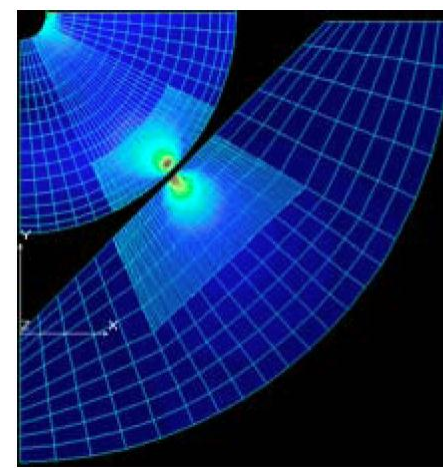

Engine Assembly Comparison

- Manufacturing

Pinned Joint

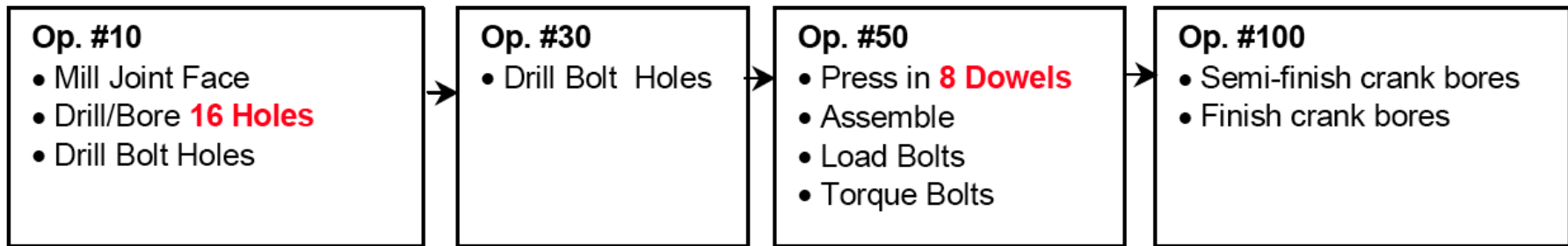

Using Quasi-KC Coupling

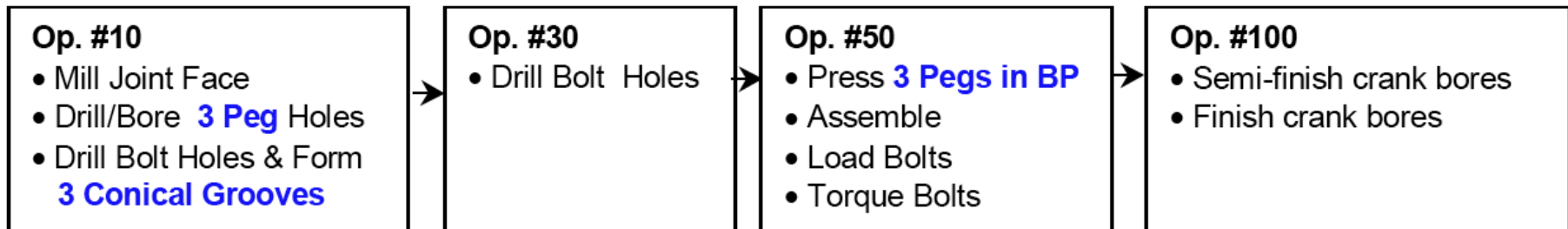

ITEM	QKC	Pinned Joints
# Precision Pieces	3	8
# Precision Features	3	16
Feature Placement Tolerance	+/- 0.08mm	+/- 0.04mm
Average Centerline Repeatability	0.65 μ m	4.85 μ m
Normalized \$/Engine	0.64	1

Servo-Controlled KC

- Michael Chiu's Doctoral Thesis
- Application: precision location and automatic leveling of precision electronic test equipment
- Teradyne has shipped over 500 systems

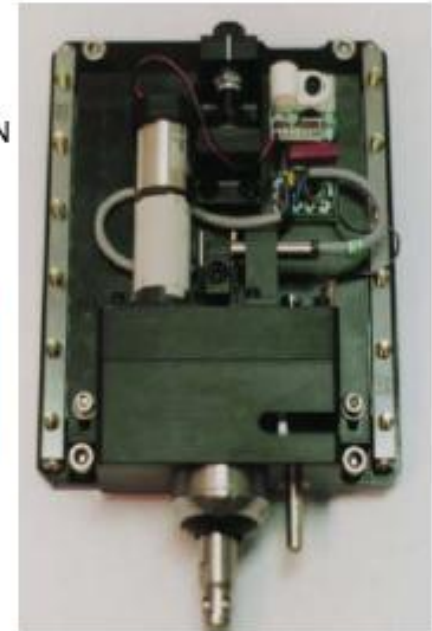
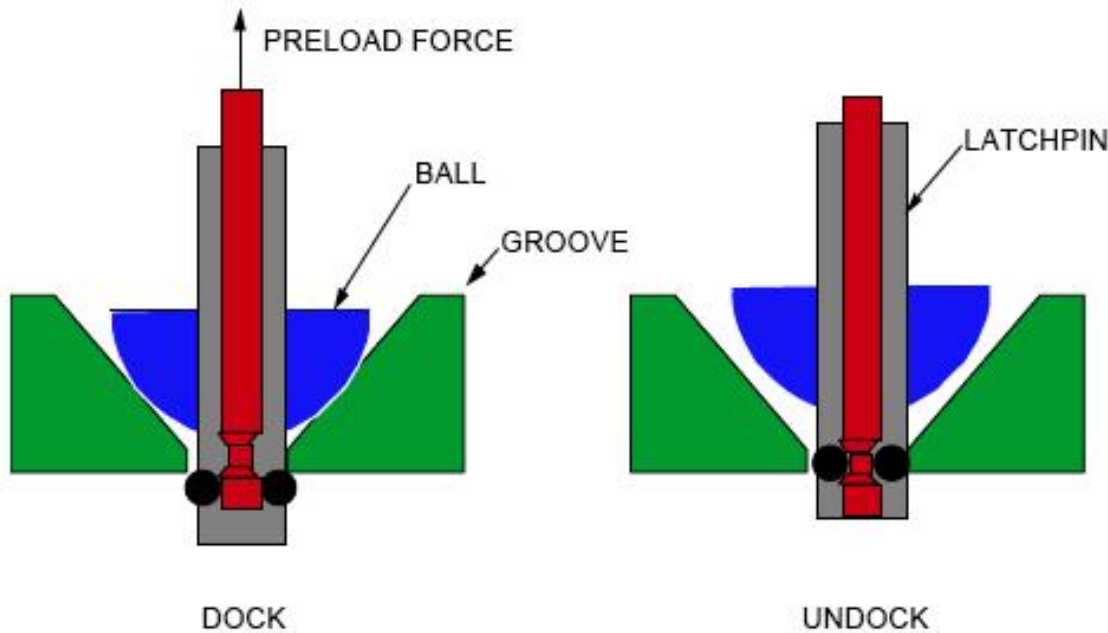

Elastic Averaging

- Multiple compliant contact points
- Members elastically deform
- High overall stiffness
- Application from toys, to office chairs to couplings

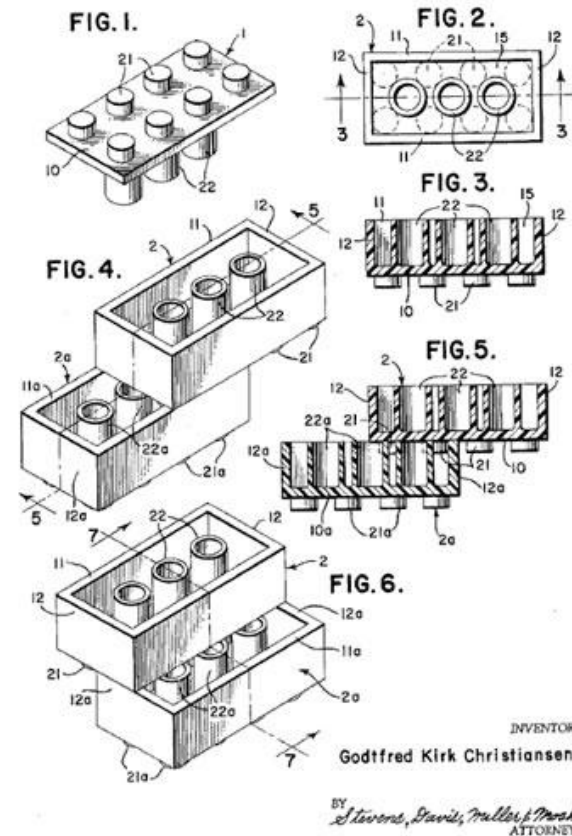
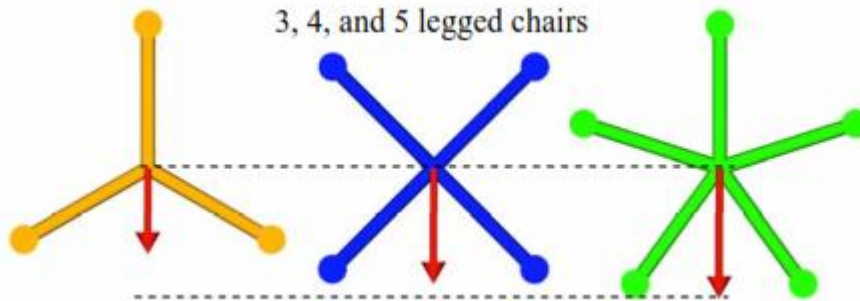

Anti Backlash Coupling

- Torsional couplings: spline, oldham, spyder



- Backlash causes noise, wear & failure
- Elastically averaged design based on multiple long, compliant fingers
- Low force, easy assembly, locked radially

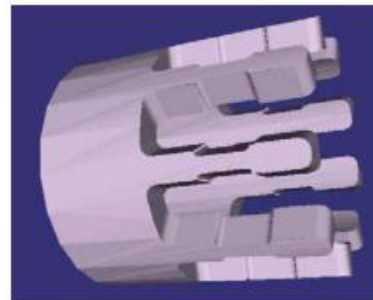
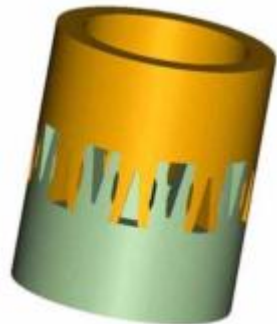

Anti Backlash Coupling

- Load carried by multiple teeth
- Compliance provided by beam bending
- Radial flex accommodates finger variation
- Fingers self lock to prevent relative slip
- Chamfered ends for assembly
- No axial forces, good damping

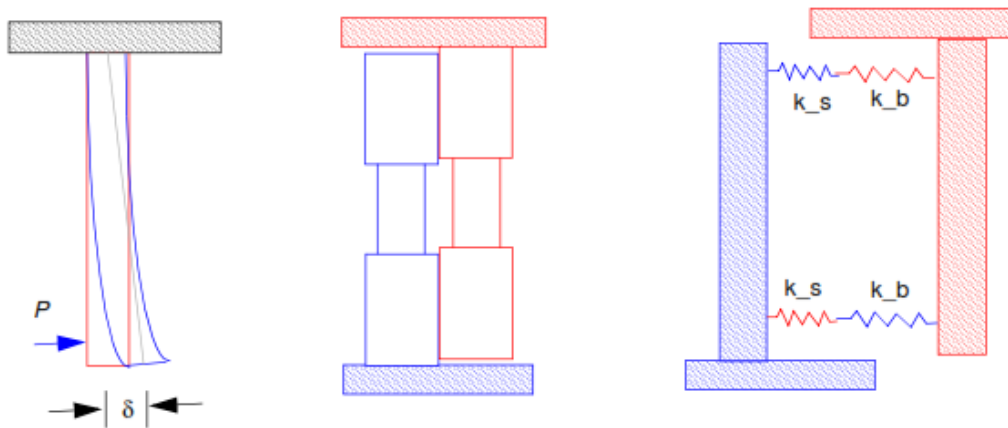
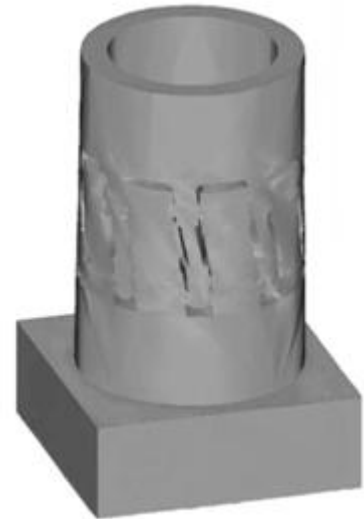

Figure 8: Finger compliance models



Thank
You

Contacts:

Nevan: hanumara@mit.edu

Folkers: folkersr@mit.edu

+1.617.258.8541